

PARÇA KODU PART CODE	PARÇA ADI PART NAME	s ÖLÇÜSÜ (KALINLIK) s MEASURE (THICKNESS)	Malzeme Material	Kaplama Coating
TŞ 2406.40 DP	1 NO KABLO UÇ Ø4.2 =DP=	0.40±0.05	(CuZn30) Pirinç / Brass	—
TŞ 2406.40 RP	1 NO KABLO UÇ Ø4.2 =RP=	0.40±0.05	(CuZn30) Pirinç / Brass	—
TŞ 2406.40 RPK	1 NO KABLO UÇ Ø4.2 =RPK=	0.40±0.05	(CuZn30) Pirinç / Brass	Kalay / Sn (3-5µ)
TŞ 2406.50 DP	1 NO KABLO UÇ Ø4.2 =DP=	0.50±0.05	(CuZn30) Pirinç / Brass	—
TŞ 2406.50 RP	1 NO KABLO UÇ Ø4.2 =RP=	0.50±0.05	(CuZn30) Pirinç / Brass	—
TŞ 2406.50 RPK	1 NO KABLO UÇ Ø4.2 =RPK=	0.50±0.05	(CuZn30) Pirinç / Brass	Kalay / Sn (3-5µ)
TŞ 2406.50 RÇN	1 NO KABLO UÇ Ø4.2 =RÇN=	0.50±0.05	Nikel kaplı çelik / Nickel plated Steel	Nikel / Ni (≥1.5µ)

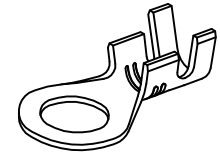

Perspektif
Perspective

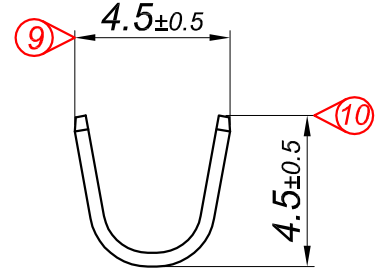
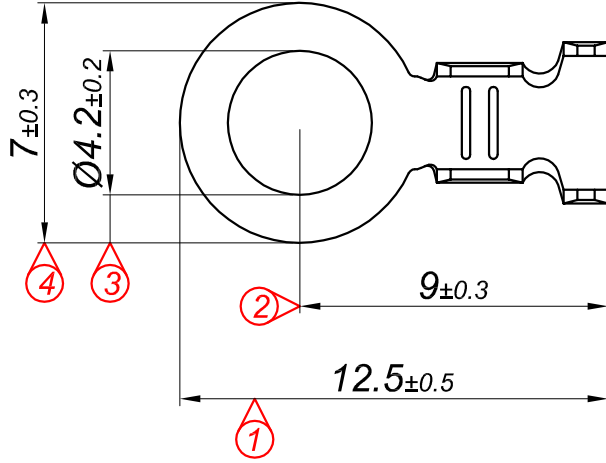
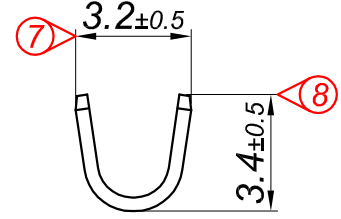
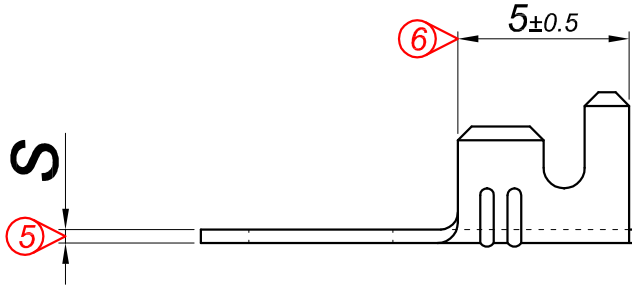
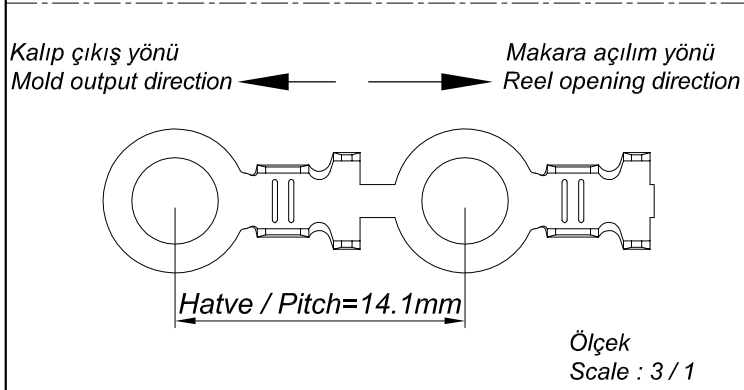

Kablo Kesiti
Wire Section : 0.50 - 1 mm²

Resim üzerinden ölçü almayınız
do not measure on drawing

Tarih / Date	19.07.2013	İmza /Signature	Ölçek /Scale			
Çizen / Desing	M.Yağcı					
Onay / Approval	S.Gölcük		5 / 1	No	Değişiklik / Revision	Tarih/Date
	Parça Adı: Part Name	1 NO KABLO UÇ Ø4.2			Parça Kodu: Part Code	TŞ 2406